

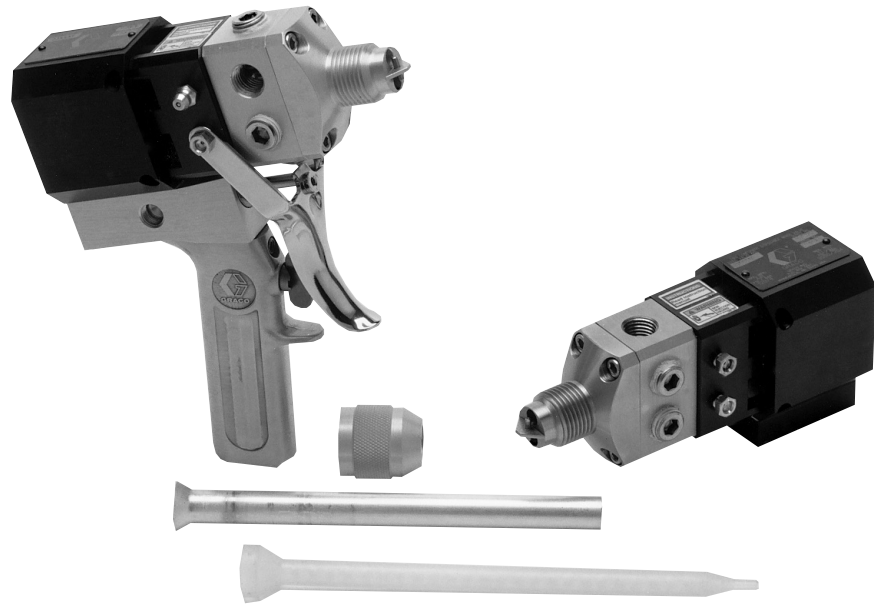

First choice when
quality counts.™

2K Ultra-Lite Valve

Automatic & Manual Two Component Applicators



**Precision
2K valve
assemblies
for mixing
two component
adhesives**

- **Severe-Duty™ needles and seats for longer operating life**
- **Lubricated packings for longer seal life**
- **Lightweight construction reduces operator/machinery fatigue**
- **Compact size for small X-Y tables, working areas and robots**
- **No purging or flushing which reduces waste disposal cost**
- **Handle kit provides easy conversion from automatic to manual**
- **Aluminum or Stainless Steel housings to handle most materials**

Graco's 2K Ultra-Lite Valve dispenses a wide range of two component (2K) adhesives and sealants for virtually every application.

The valve fluid passages can dispense two component metered fluids into a low-cost

disposable mixer selected for your operation. Combined with high quality metering, this gives you the best mixed material quality available for your product.

The Graco 2K Ultra-Lite Valve is designed as one portion of a total solution

for your two component operation. This valve can be combined with a fixed or variable ratio Hydra-Cat, Hydra-Mate, Mini-Mate or 8900 Meter to create an efficient 2K system in order to reduce the operating cost of your line. Contact your Graco representative for details.

Typical Applications

- Dispensing potting compounds into electrical hardware and components
- Dispensing gasketing materials onto plastic, metal or glass substrates
- Dispensing structural adhesives to replace fasteners or welds
- Dispensing two part sealants in assembly or fabricating operations

Typical Two Part Materials Handled

- Acrylic
- Butyl
- Epoxy
- Polysulfide
- Silicone
- Urethane

Technical Specifications

Max. Fluid Inlet Pressure 3000 psi (209 bar)
Fluid Viscosity Range 20 cps to 1 million cps
Fluid Ratio Range 1:1 to 20:1
Fluid Inlet Ports: (2) Resin, (2) Catalyst 1/4 npt(f)
Snuffer Action Fluid Section dual seal isolation chambers with Zerk fittings

Max. Cylinder Air Pressure 120 psi (8 bar)
Air Inlet Ports: (1) Open, (1) Close 1/8 npt(f)
Divorced Air Cylinder dual piston cylinder, EP O-rings
Pistol Grip Kits

Pneumatic Handle Kit single line, 120 psi max, 1/8 npt(f) inlet
Electric Handle Kit 24 VDC or 120 VAC, 3 amp max

Severe-Duty™ Components

Shafts (2) Hard Chrome over 303 SST
Snuffer Needles (2) Hardened 17-4pH SST
Seats (2) reversible, solid C2 carbide inserts
Shaft Seals (2): Standard . .high density Parker Polymyte™
Shaft Seals (Optional) UHMWPE or Teflon®

Size of 2K Ultra-Lite Valve

Automatic 6.07 in. L x 1.75 in. W x 2.00 in. H
Manual 6.07 in. L x 1.75 in. W x 6.96 in. H

Weights

Aluminum 1.43 lbs (0.65 kg)
SST 2.07 lbs (0.94 kg)
Pistol Grip Handle Kit 0.77 lbs (0.35 kg)

Wetted Parts

Aluminum aluminum, 303 SST, 17-4pH SST, C2 carbide hard chrome, ethylene propolyene, Parker Polymyte, Teflon
SST 303 SST, 17-4pH SST, C2 Carbide, Hard Chrome, ethylene propolyene, Parker Polymyte™, Teflon

Mounting Holes two .25 dia. holes thru cylinder for (2) 1/4 screws spaced 1.375 in. apart

Disposable Mixers Data Sheet Form No. 305-753

Instruction Manual Graco Chicago Form 684-009

Parker Polymyte™ is a registered trademark of Parker Hannifin Corp.
Teflon® and Viton® are registered trademarks of Du Pont.

Accessories

Plastic Tubing Air Lines

513-063 1/8 in. OD nylon
514-607 5/32 in. OD nylon
513-231 1/4 in. OD nylon

551-201 Air Cylinder Speed Control 90° Fitting

Inlet: 1/8 npt(f). Outlet: 1/8 npt(m).
Mount on “close” port to control opening speed for soft start; mount on “open” port to control closing speed for less snuff-back

104-661 Quick Exhaust Valve

Inlet and outlet: 1/8 npt(f). Exhaust: 1/4 npt(m).
To speed up opening or closing action of the 2K Ultra-Lite Valve

104-632 Pump Pilot Valve

Line ports: 1/2-in. npt(f). Pilot port: 1/8 npt(f).
Three-way air piloted air valve to turn air-powered proportioning pump on with hand gun signal.

Solenoids (Four-way valves to operate 2K Ultra-Lite)

626-144 Manifold to direct mount solenoid to 2K UL Valve.
551-316 120V AC solenoid for 626-144 manifold.
551-317 24V DC solenoid for 626-144 manifold.
551-347 120V AC solenoid remote mount (1/8 npt(f) ports).
551-348 24V DC solenoid remote mount (1/8 npt(f) ports).
551-349 120V AC din plug with screw terminals for above solenoids.
551-350 24V DC din plug with screw terminals for above solenoids.

Inlet Check Valves

Maximum working pressure: 3000 psi (209 bar)
501-867 1/4 npt (m x m). 303 SST with Teflon O-ring poppet (2 psi crack pressure)
551-302 1/4 npt (m x m). 316 SST with Viton® O-ring (50 - 150 psi adjustable crack pressure)
501-684 3/8 npt (m x m). 303 sst with Teflon O-ring poppet (2 psi crack pressure)
949-709 3/8 npt (m x m). Carbon steel carbide seat (50 psi crack pressure)
949-710 3/8 npt (m x m). Carbon steel carbide seat (100 psi crack pressure)

Plastic Tube Fittings (connects air lines to valve)

| Tube OD | 1/8 npt(m) Straight | 1/8 npt(m) 90° Swivel | Tube Tee |
|----------|---------------------|-----------------------|----------------|
| 1/8 in. | — | 513-826 | 551-203 |
| 5/32 in. | 598-329 | 598-140 | 514-435 |
| 1/4 in. | 104-172 | 597-151 | 111-167 |
| Tube OD | 1/4 npt(m) Straight | 1/4 npt(m) 90° Swivel | |
| 5/32 in. | 598-252 | 598-327 | |
| 1/4 in. | 104-165 | 598-156 | |

626-076 Dual Outlet Nose Piece

Has two 1/4 npt(f) outlets for ratio checking or recirculation of independent components.

551-351 Short Throw Spacer

Added under the air piston in the valve to limit how far the fluid needles push open. It reduces the amount of material surge when the valve opens, and reduces the amount of snuff-back available. Used for dispensing low flow small diameter beads.

551-327 Nightcap

Plastic cap to cover nose piece outlet when valve is not in use. Disposable.

Optional Main Fluid Needle Packings

551-192 Urethane U-cup with EPDM O-ring spreader.

551-193 Reinforced Teflon U-cup with 302 SST spreader.

Mixer Accessories



Complete Assembled Unit

Disposable Mixers

| ID | OD | Part No. | No. of Elements | Part No. | No. of Elements | Part No. | No. of Elements |
|------|------|----------------|-----------------|----------------|-----------------|----------------|-----------------|
| 3/16 | 0.30 | 551-337 | 16 | 551-338 | 24 | 551-339 | 32 |
| 1/4 | 3/8 | 512-012 | 16 | 512-013 | 24 | 512-014 | 32 |
| 3/8 | 1/2 | 512-015 | 18 | 512-016 | 24 | 512-017 | 30 |
| 1/2 | 5/8 | 512-287 | 18 | 512-288 | 24 | 512-289 | 30 |



Disposable Steel Jacket, Retaining Nut

Steel Jackets

| | Jacket. Part No. | Fits Mixer. Part No. | Jacket Part No. | Fits Mixer Part No. | Jacket Part No. | Fits Mixer Part No. |
|--------------------|------------------|----------------------|-----------------|---------------------|-----------------|---------------------|
| Fits .30 OD Mixer | 551-340 | 551-337 | 551-341 | 551-338 | 551-342 | 551-339 |
| 1/2 OD fits 3/8 OD | 512-876 | 512-012 | 512-293 | 512-295 | 512-294 | 512-014 |
| 5/8 OD fits 1/2 OD | | | 515-295 | 512-016 | 512-008 | 512-017 |
| Fits 5/8 OD Mixer | 512-296 | 512-287 | 512-297 | 512-288 | 512-298 | 512-289 |

Jackets for 5/8 OD Mixers are one piece including a retaining nut.

Retaining Nuts

512-290 Fits up to 3/8 OD mixers or jackets

512-291 Fits 1/2 OD mixer, or jacket from 1/4 ID mixers

512-292 Fits 5/8 OD mixer, or jacket from 3/8 ID mixers

SEALANT ADHESIVE EQUIPMENT

Ordering Information

2K Ultra-Lite Valves

- 965-533** Automatic 2K Ultra-Lite Valve with Aluminum Housing
- 965-534** Automatic 2K Ultra-Lite Valve with Stainless Steel Housing
- 965-535** Pistol Grip / Pneumatic Switch 2K Ultra-Lite Valve with Aluminum Housing
- 965-536** Pistol Grip / Pneumatic Switch 2K Ultra-Lite Valve with SST Housing
- 965-537** Pistol Grip / Electric Switch 2K Ultra-Lite Valve with Aluminum Housing
- 965-538** Pistol Grip / Electric Switch 2K Ultra-Lite Valve with Stainless Steel Housing



Pistol Grip / Pneumatic Switch 2K Ultra-Lite Valve

Pistol Grip Kits

- 949-631 Pneumatic Handle Kit**
Attaches to any automatic 2K Ultra-Lite valve. Includes handle, trigger and 4-way valve inside handle.
- 949-632 Electric Handle Kit**
Attaches to any automatic 2K Ultra-Lite valve. Includes handle, trigger, cable with connector and switch inside handle.

Repair Kits

- 949-633 Fluid Section Seal Kit.**
Consists of O-rings and seals for the fluid section of the valve.
- 949-634 Valve Rebuild Kit**
Consists of needles, seats, bearings, O-rings and seals for the air cylinder and fluid section.
- 626-058 Restrictor for Nose Piece**
1/8 in. (0.125 in.) ID
- 626-059 Restrictor for Nose Piece**
3/64 in. (0.047 in.) ID; uses O-ring 103-154



Automatic 2K Ultra-Lite Valve